

SUPER DRILL

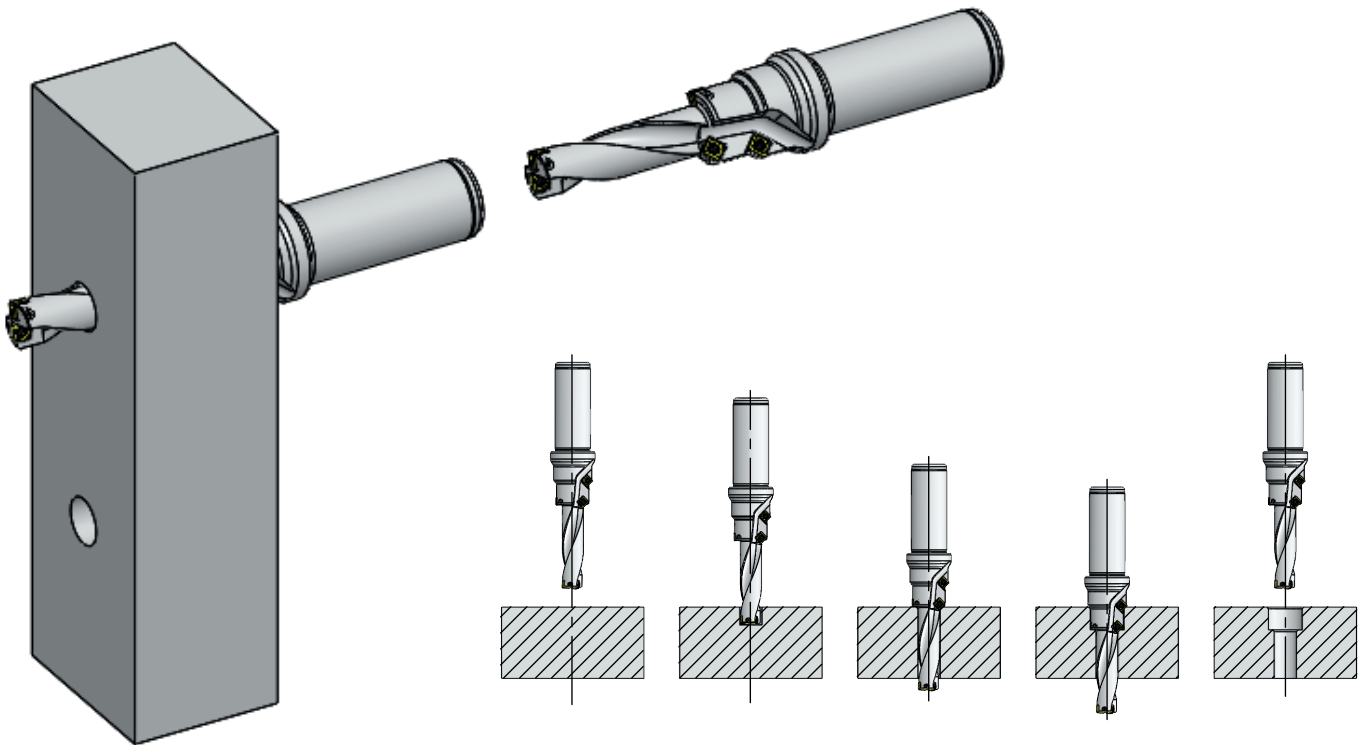

1 *Min.*

FOR IMBUS BOLTS:
*Process time 1 minute
with superdrill, which makes
four bore-piercing operations*



IMBUS BOLT-STAGE DRILLING TOOLS TECHNICAL TABLE

• Super Drill

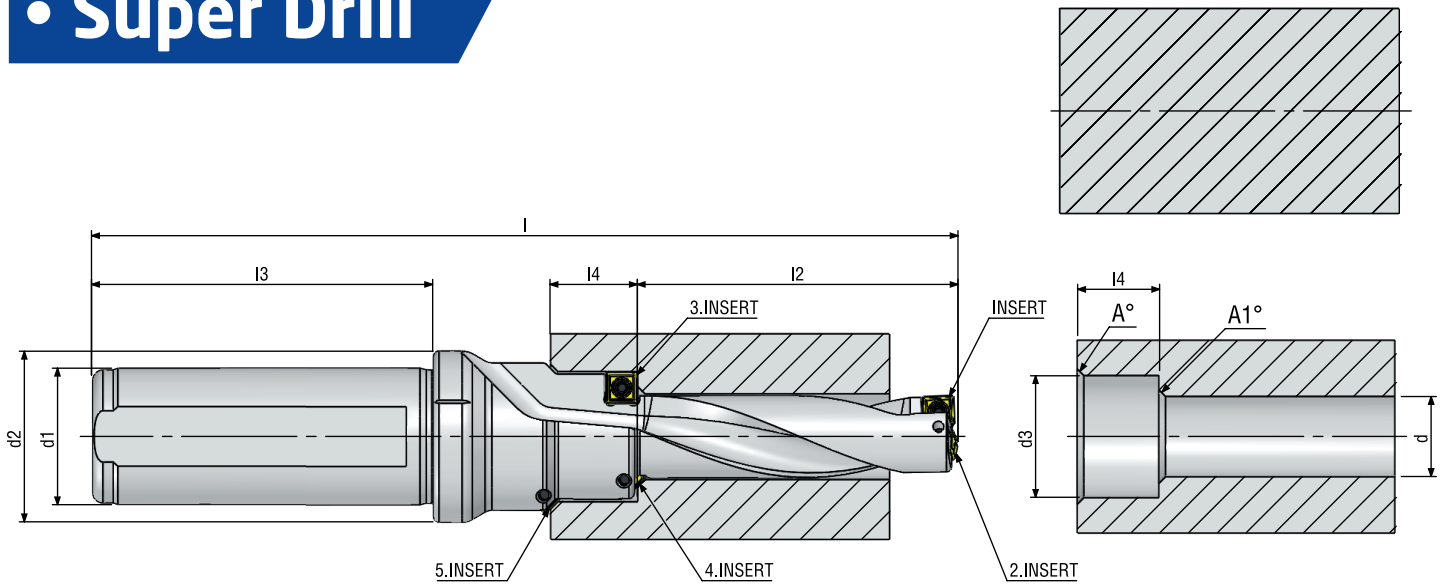

AKKO CODE	d	d1	d2	d3	l	l2	l3	l4	A°	A1°	INSERT	2.INSERT	3.INSERT	4.INSERT	5.INSERT
OTBA-12.5X47-C1-19X13-C1.2-W20	12,5	20	25	19	127	47	50	13	1,2*45	1*45	SPMT 040204	XOMT 040204	SPMT 040204	SPMT 040204	SPMT 040204
OTBA-12.5X47-C1-19X13-C1.2-W20-CCMT	12,5	20	25	19	127	47	50	13	1,2*45	1*45	SPMT 040204	XOMT 040204	CCMT 060204	SPMT 040204	SPMT 040204
OTBA-16.5X47-C1-25.5X15-C1.2-W25	16,5	25	34	25,5	140	47	56	15	1,2*45	1*45	SPMT 060205	XOMT 060204	CCMT 060204	SPMT 060205	SPMT 060205
OTBA-25X58-C1.2-37.5X25-C1.5-W32	25	32	44	37,5	170	58	60	25	1,5*45	1,2*45	SPMT 090308	XOMT 090305	CCMT 09T308	SPMT 07T208	SPMT 07T208
OTBA-27.5X61.5-C1-33X6.5-C1.2-W32	27,5	32	44	33	162	61,5	60	6,5	1,2*45	1*45	SPMT 090308	XOMT 090305	CCMT 060204	SPMT 07T208	SPMT 07T208
OTBA-33.5X66.5-C1-39X8.5-C1.5-W32	33,5	32	44	39	165	66,5	60	8,5	1,5*45	1*45	SPMT 11T308	XOMT 11T305	CCMT 060204	SPMT 07T208	SPMT 07T208

IMBUS BOLT SLOT DRILLING (HEAD PRESSING) TOOLS TECHNICAL TABLES

• Super Drill

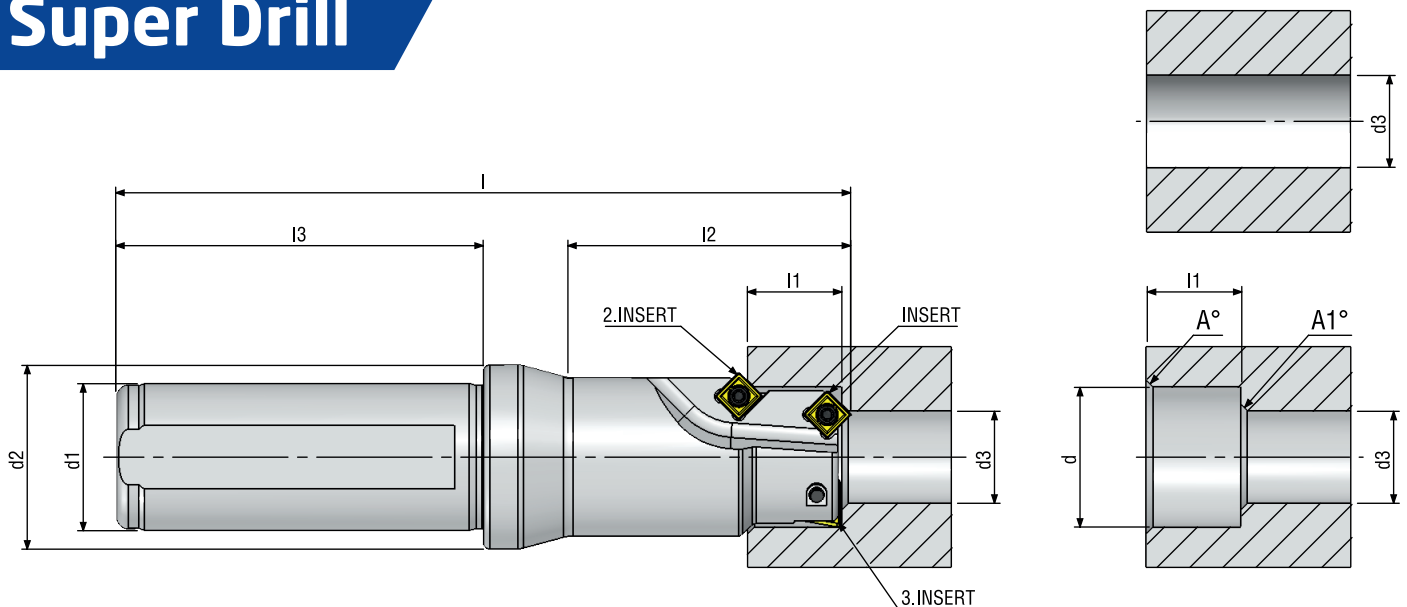

AKKO CODE	d	d1	d2	d3	l	l1	l2	l3	A°	A1°	INSERT	2.INSERT	3.INSERT
OTB-12.5-C1-19X13-C1.2-W20	19	20	25	12,5	100	13	38,5	50	1,2*45	1*45	SPMT 040204	SPMT 040204	CCMT 060204
OTB-16.5-C1-25.5X15-C1.2-W25	25,5	25	34	16,5	100	15	30,5	56	1,2*45	1*45	SPMT 060205	SPMT 060205	CCMT 060204
OTB-21-C1-31X21-C1.2-W25	31	25	34	21	100	21	22,5	56	1,2*45	1*45	SPMT07T208	SPMT07T208	CCMT 060204
OTB-25-C1.2-37.5X25-C1.5-W32	37,5	32	44	25	110	25	42	60	1,5*45	1,2*45	SPMT07T208	SPMT07T208	CCMT 09T308
OTBA-27.5X61.5-C1-33X6.5-C1.2-W32	47	32	49	31	120	31,5	33	60	1,2*45	1,2*45	SPMT07T208	SPMT07T208	CCMT 09T308