

# MUT-600 Manual Turn Table



## Application / Benefits

High Accuracy by Special Curvic Coupling  
Easy to Heavy cutting and boring, Powerful clampingBody

## Model No.

**MUT-600**

Table Diameter  
TYPE : Rear Mounted Motor NC Rotary Table

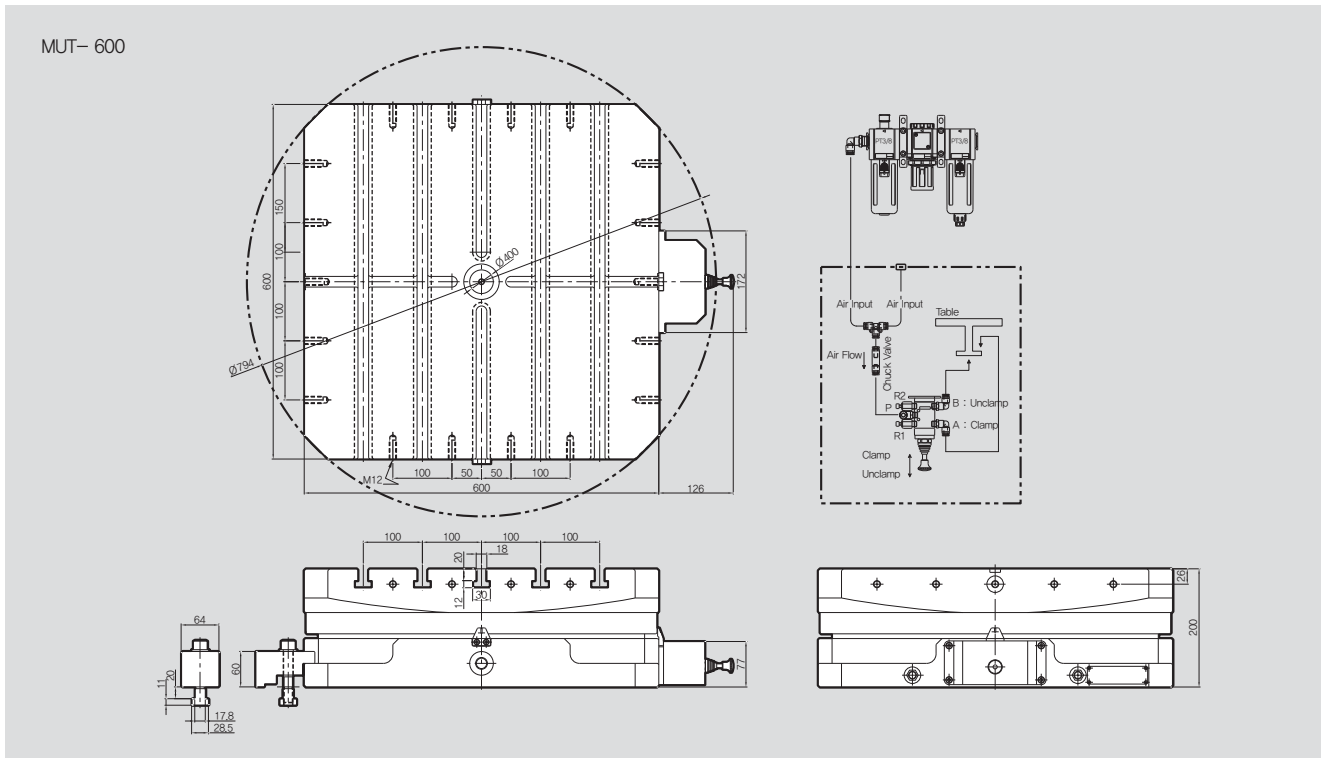

NC Rotary Table

## SPECIFICATIONS

Table Dia. [mm]	600 x 600
Center-Hole Dia. [mm]	Ø40
Rounded Corners [mm]	Ø794
Height [mm]	200
Driving Method	Pneumatic 7kg/cm <sup>2</sup>
Allowable Work Inertia [kgm <sup>2</sup> ]	90
Clamp Capacity [kgf]	3200
Width of T-slot [mm]	20H7
Indexing Accuracy [sec]	6
Min. Increment [deg.]	1° or 5°

Max. Thrust Load	Axial Force F		3500
	Radial Moment FxL		140
	Tilting Moment FxL		220
Max. Work Load	F x L [N-m]		2000
Weight	F x L [N-m]		400