

PKF Air-operated high-precision chuck



APPLICATION

Suitable for very high concentricity and clamping repeatability.

TYPE

Air-operated high precision wedge hook clamping chuck.

CUSTOMER BENEFITS

- ③ Concentricity and axial run-out precision within 0.003 mm
- ③ High amount of safety in event of pressure failure thanks to self-locking
- ③ Low-maintenance thanks to oil-mist lubrication
- ③ Optimal adaption of the clamping force for clamping deformation-sensitive parts thanks to large actuation range from 2-10 bar

TECHNICAL FEATURES

- Clamping piston construction with power transmission on both sides according to the ROHM KFD-HS principle
- Integrated pneumatic operation
- Through-hole for coolant supply for sizes 100-200

Note:

Please order air supply tube, maintenance unit, top jaws and actuation valves separately



PKF air-operated high-precision chuck

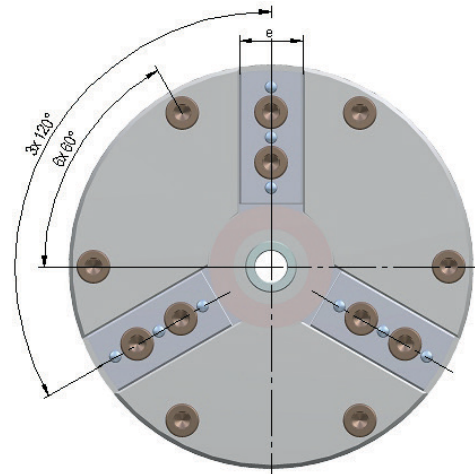
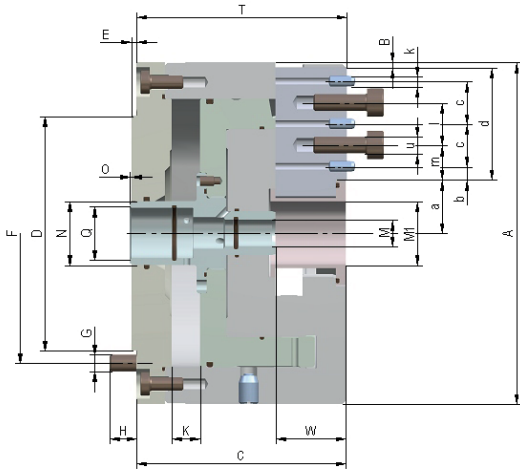

C 15
High-precision air-operated lathe chuck PKF, concentricity 0.003 mm, repetitive clamping accuracy 0.0015 mm with through-hole, pneumatically operated, with integrated pneumatic piston, clamping precision in the μ range

Item no.	153706 ▲	153707 ▲	153708 ▲	153709 ▲	153710 ▲
Size	100	100	150	150	200
A mm	102	102	151	151	202
Jaw travel B mm	0,75	1,5	0,75	1,5	1,5
C mm	52,5	62,5	52,5	62,5	85,5
D-0,01	82,55	82,55	124,97	124,97	167,64
E mm	1,5	1,5	1,5	1,5	3,2
F mm	88,9	88,9	135,9	135,9	182,9
G	M5	M5	M6	M6	M10
H mm	8	8	9	9	16
Wedge stroke K mm	4,25	8,5	4,25	8,5	8,5
M mm	3,2	3,2	3,2	3,2	3,2
M1 mm	19	19	25,4	25,4	25,4
N mm	19	19	19	19	19
O min.	0,5	0,5	0,5	0,5	0,5
O max.	4,75	9	4,75	9	9
Q mm	5/8"	5/8"	5/8"	5/8"	5/8"
W mm	19	19	19	19	35
T mm	52,8	62,8	52,8	62,3	85,9
a min.	16,75	16	22,75	22	21,9
a max.	17,5	17,5	23,5	23,5	23,4
b mm	3,9	3,9	14,9	14,9	4,5
c mm	2 x 12,7	2 x 12,7	2 x 12,7	2 x 12,7	2 x 31,75
d mm	33,5	33,5	52	52	76,1
e mm	16	16	24	24	32
k mm	1/8"	1/8"	1/8"	1/8"	1/4"
l mm	12,7	12,7	3 x 12,7	3 x 12,7	31,75
m mm	10,25	10,25	8,55	8,55	20,375
u	2 x M5	2 x M5	4 x M5	4 x M5	M10
Operating pressure bar	2-10	2-10	2-10	2-10	2-10
Area A1 clamping cm ²	47,4	47,4	100	100	185,0
Area A2 releasing cm ²	28,9	28,9	69	69	111,5
Total clamping force at 8 bar kN	13	13	27	27	31,5
Max. admissible speed at 8 bar min ⁻¹	5500	5500	4000	4000	3000
Moment of inertia J kgm ²	0,0029	0,0029	0,015	0,015	0,08
Weight kg	2,3	2,3	5,5	5,5	16

Higher speeds available on request

Power chucks with through-hole PKF

Jaws PKF

C 21
Soft top jaws steel version, set of 3-jaws



Item no.	Chuck Size	Jaw length mm	Jaw height mm	Jaw width mm
153818 ▲	100	49	25	18,4
153819 ▲	150	74	30	26,5
153820 ▲	200	95	46	34,7

Accessories PKF

C 15
Air-operated control LSG R 1/4 up to 10 bar, for air-operated power chucks



Item no.	Width mm	Height mm	Depth mm	Control voltage	Conn. thread
437107 ▲	380	380	210	24V DC	R 3/8" internal

Other control voltage on request

C 15
Service unit for air operated control
Separator and filtre CKS-08/10 and lubricator CL-08/10



Item no.	Width mm	Height mm	Depth mm
216084 ▲	130	240	102

Max. flow Qn 33m³/h at 6 bar

C 15
Manually operated air control valve LHV with 2 switch settings and a safety switch lever



Item no.	Width mm	Height mm	Depth mm	Conn. thread internal	Conn. thread external
418224	66,5	64	38	R 1/4 "	M 16 x 1,5

Configure your individual clamping jaws online! www.web2product.biz

Accessories PKF

Air supply tube

Air supply tube 3/8" and 5/8"
 Type 586-80
 Max. speeds = 10 000 min⁻¹
 Central through-hole for air
 and coolant.
 Max. air pressure = 10 bar

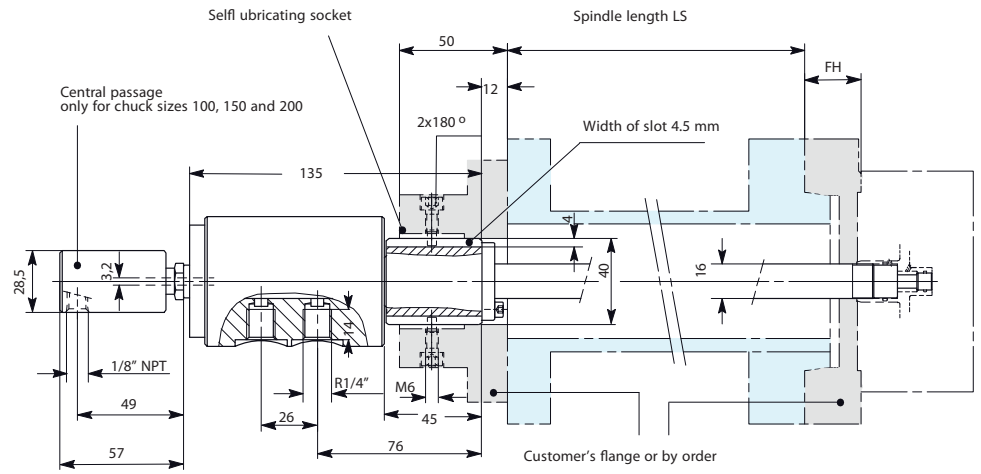

Ordering indications for air supply tube:

Chuck size + spindle length LS + height of flange FH