

PROVEN WEDGE HOOK SYSTEM

Founded in 1909, RÖHM began successively expanding their product range by the area of power chuck technology starting in 1950. Decades of experience and knowledge about power chucks make today's RÖHM power chucks so successful. These are not only characterized by their long service life, but also by the top precision and reliability.

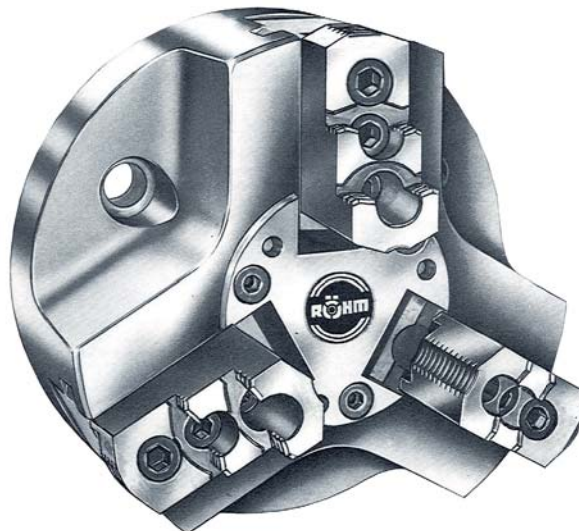

Power chuck KFD with wedge hook system without through-hole

POWER CHUCKS WITHOUT THROUGH-HOLE

The RÖHM power chucks without through-hole have already been used for decades and have proven themselves many times over in various clamping tasks. Thanks to the wedge hook system as well as the rigid chuck construction, the power chucks achieve a high load capacity and clamping precision along with a long service life.

ADVANTAGES AT A GLANCE

- ⊕ Proven power chucks with long service life
- ⊕ Wedge hook system for high load capacity and clamping precision
- ⊕ Simple setup as basis for a wide range of applications

High load capacity thanks to proven wedge hook system

Different toothing types for different jaw variants

Protection against dirt and chips with cover

Rigid chuck construction for high clamping precisions

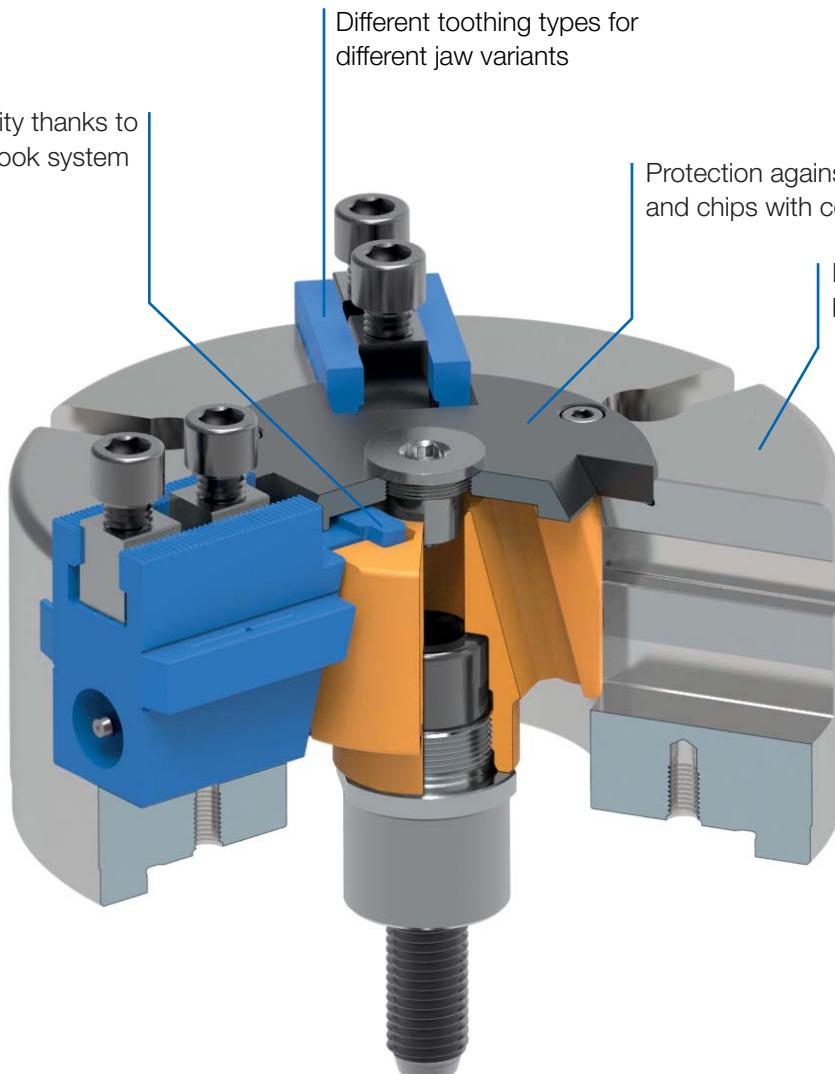

KFD-EC



APPLICATION

Especially for use under extreme operating conditions, e.g. dry or raw part machining and/or high coolant pressure.

TYPE

Power chuck with cylindrical center mount.
3-jaw version with serration (90°).

CUSTOMER BENEFITS

- ③ Easy Care: Low-maintenance and -wear
- ③ Lubrication interval, depending on operating conditions, up to approx. 600 operating hours
- ③ Optimized protection against the penetration of dirt thanks to seals built into the jaw guides

TECHNICAL FEATURES

- Proven wedge hook system

Note:

KFD-EC with centrifugal force compensation on request

Structure KFD-EC

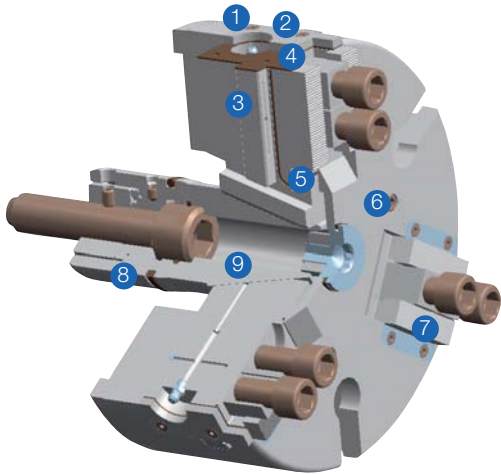

- ① Body
- ② End cover
- ③ Base jaw
- ④ Flat seal
- ⑤ Square ring
- ⑥ Cover
- ⑦ Wiper plates
- ⑧ O-Ring
- ⑨ Piston

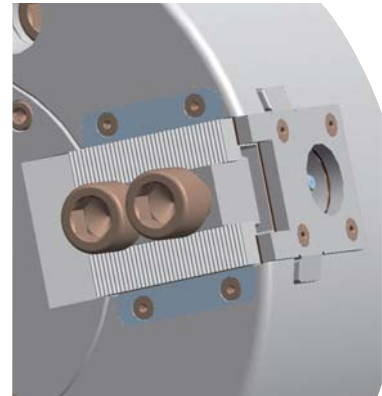

KFD-EC 3-jaw, serration 90°

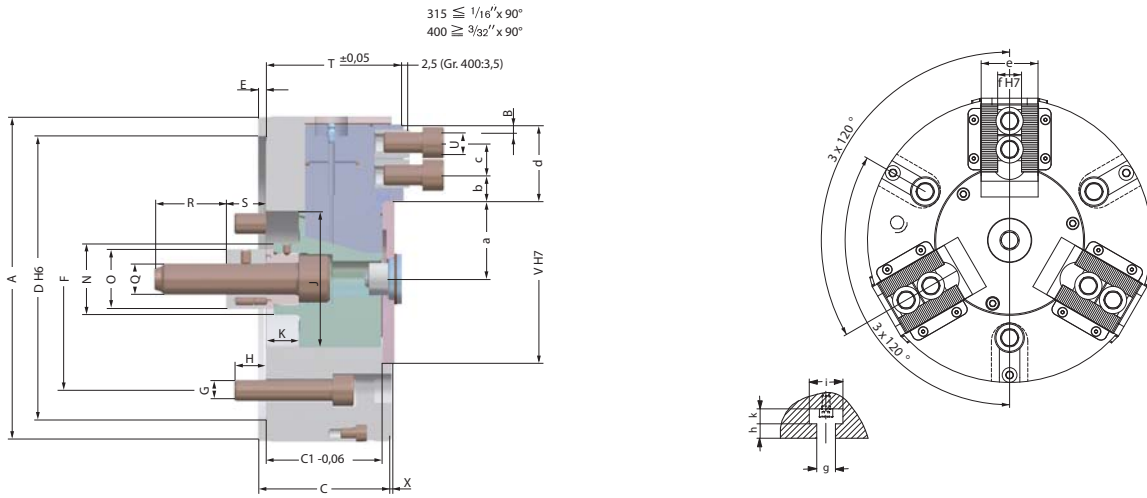

Low-Maintenance 3-jaw power chuck KFD-EC, with short piston, without force compensation, centric clamping
 Adaptor recess, mounting dimensions to DIN 6353

Item no.	166183	166184	166185	166186
Size	200	250	315	400
A mm	200	250	315	400
Jaw travel B mm	6,7	6,7	8	9,3
C mm	86	98	113	121
C1 -0,06 mm	80	92	107	115
Mount DH6	170	220	300	300
E mm	6	6	6	6
F mm	133,4	171,4	235	235
G mm	3xM12	3xM16	3xM20	3xM20
H mm	18	23	31	30
J mm	85	105	120	155
Wedge stroke K mm	25	25	30	35
N mm	45	55	60	60
O mm	40	46	46	55
Q mm	M20	M24	M24	M24
R mm	45	55	55	55
S min.	30	30	30	30
S max.	55	55	60	65
T±0,05 mm	90	105	120	130
U	M12x25	M16x30	M16x30	M20x40
VH7 mm	110	130	160	190
X mm	7	7	9	9
a min.	43,3	53,3	59,5	77,7
a max.	50	60	67,5	87
b min.	8	10	10	14
c min.	19	25	25	31
c max.	34,5	47,5	70,5	87
d mm	45	59	84	107
e mm	35	50	55	60
fH7 mm	17	21	21	25,5
g mm	14	18	18	22
h mm	11	13	13	22
i mm	11	14	14	18
k mm	25	32	32	40
Maximum draw bar pull kN	45	65	80	95
Max. total clamping force kN	90	140	190	250
Max. admissible speed min-1	4000	3200	2800	2000
Moment of inertia J kgm ²	0,1	0,28	0,89	2,02
Weight without jaws approx. kg	19,3	34,8	63,6	88,4
Actuating cylinders (recommended)	OVS-130	OVS-150	OVS-150	OVS-200

Intermediate adaptors for short taper mount on request

Power chuck without through-hole KFD-EC

Jaws KFD-EC

C 21

Reversible top jaws, 3-jaw set, hardened serration 90° - material: 16 MnCr 5



Item no.	Chuck Size	Jaw length mm	Jaw height mm	Jaw width mm	Serration
118522	200	75	49	36	1/16"x 90°
046414	250/315	103,5	58	50	1/16"x 90°
037531	400	135	65	68	3/32"x 90°

Additionally or later applied, hardened jaws must be ground out in the chuck.

C 21

Soft top jaws, 3-jaw set, can be hardened serration 90° - material: 16 MnCr 5



Item no.	Chuck Size	Jaw length mm	Jaw height mm	Jaw width mm	Serration
133153	200	75	53	36,5	1/16"x 90°
133154	250	95	54,5	45	1/16"x 90°
133155	315	103	80	50	1/16"x 90°
133156	400	130	80	50	3/32"x 90°

C 21

Claw-type jaws, 1 piece, hardened serration 90° - width of the groove 17



Item no.	Chuck Size	Jaw length mm	Jaw height mm	Claw length mm	Serration
137031	200	67	45	53	1/16"x 90°
137032	200	65	45	46	1/16"x 90°
137033	200	55	45	39	1/16"x 90°
137034	200	50	45	31	1/16"x 90°
137035	200	55	45	27	1/16"x 90°
137036	200	65	45	19	1/16"x 90°
137037	200	65	45	26	1/16"x 90°
137038	200	55	45	24	1/16"x 90°
137039	200	55	45	40	1/16"x 90°

C 21

Claw-type jaws, 1 piece, hardened serration 90° - width of the groove 21



Item no.	Chuck Size	Jaw length mm	Jaw height mm	Claw length mm	Serration
137041	250/315	95	50	80	1/16"x 90°
137042	250/315	75	50	60	1/16"x 90°
137043	250/315	60	50	43	1/16"x 90°
137044	250/315	70	50	37	1/16"x 90°
137045	250/315	95	50	25	1/16"x 90°
137046	250/315	80	50	30	1/16"x 90°

C 21

Claw-type jaws, 1 piece, hardened serration 90° - width of the groove 25,5



Item no.	Chuck Size	Jaw length mm	Jaw height mm	Claw length mm	Serration
137051	400	130	65	113	3/32"x 90°
137052	400	90	65	67	3/32"x 90°
137053	400	100	65	45	3/32"x 90°
137054	400	130	65	33	3/32"x 90°

Accessories KFD-EC

C 15

T-nuts
With screw

Item no.	Contents of delivery	D mm	E
241674	piece	17	M12x25
241675	piece	21	M16x30
241676 ¹⁾	piece	25,5	M20x40

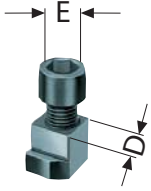

C 15

Special grease F80 for lathe chucks
for lubrication and conservation of clamping force

Item no.	Design	Contents
028975	Tin	1 kg
308555	Cartridge	0,5 kg



Accessories KFD-EC

C 15

Intermediate adaptor plates with cylindrical centre mount DIN 6353 for 3-jaw chucks
Mounting from front to ISO 702-1 (DIN 55026/55021) and ASA B 5.9 A1/A2 with metric mounting bolts

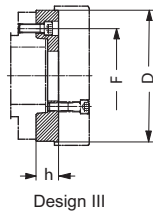
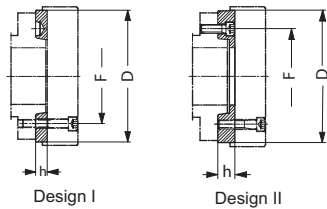

Item no.	Spindle nose size	Size	Design	h mm	F mm	D mm
145127	5	200	II	21	104,8	170
145155	6	200	I	16	133,4	170
145131	6	250	II	27	133,4	220
145135	8	200	III	39	171,4	170
145157	8	250	I	18	171,4	220
145137	8	315/400	II	38	171,4	300
145143	11	250	III	48	235	220
145159	11	315	I	19	235	300
145149	15	400	III	58	330,2	300

All fastening parts are included
Intermediate adaptor plate for 2- and 4-jaw version on request



APPLICATION

Standard power chuck without through-hole for various clamping tasks.

TYPE

Power chuck available with cylindrical center mount.
 3-jaw version with serration (90°) or tongue and groove.
 2-jaw and 3-jaw version with serration (90°) and weight reduction.

CUSTOMER BENEFITS

- ⊕ Long service life - all moving parts are hardened and ground
- ⊕ High clamping precision thanks to proven wedge hook system

TECHNICAL FEATURES

- Power transmission by means of powerfully dimensioned wedge hook system
- Direct lubrication of the base jaws
- Starting from size 200 with roller for limiting the jaw movement
- The forward movement of the piston is stopped in the cylinder, movement toward the rear is stopped at the spindle or spindle flange

Gripping force/speed diagrams

The loss of gripping force was determined experimentally on a chuck with matched UB top jaws. It is largely independent of the initial gripping force at zero speed.

Upper curve:
min. centrifugal force of top jaw



Lower curve:
max. centrifugal force of top jaw



To obtain the specified gripping forces, the chuck must be in a perfect condition and lubricated with F 80 lubricant recommended by RÖHM. Measuring point near chuck face.

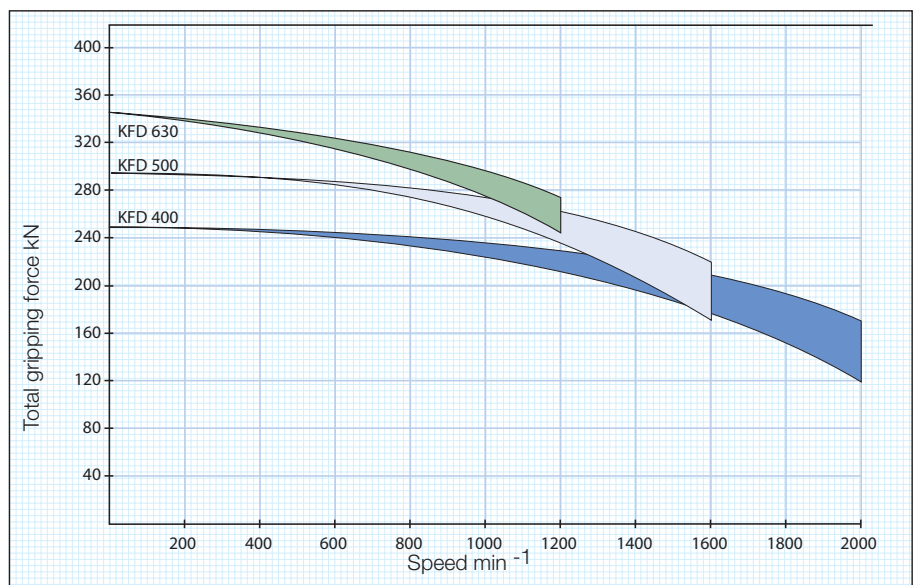
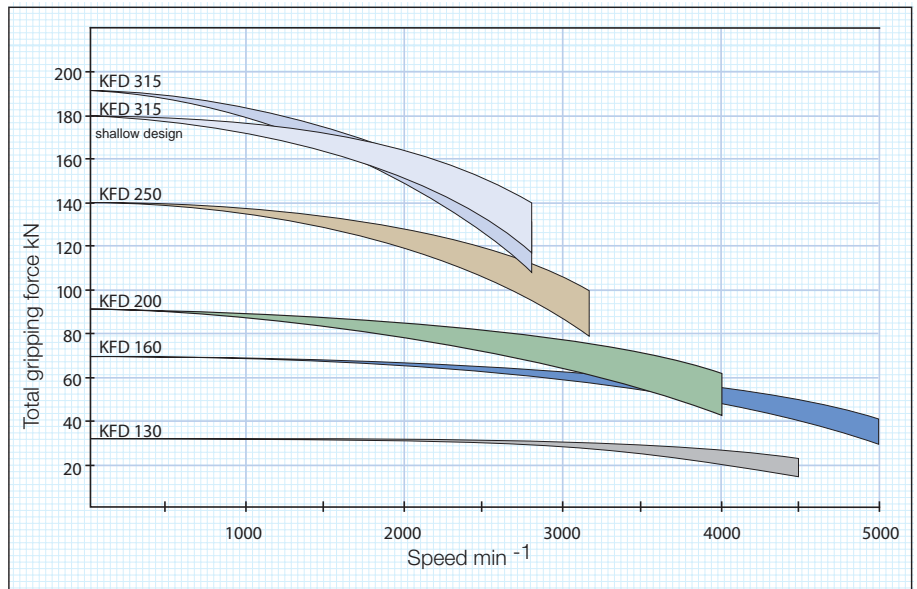

KFD

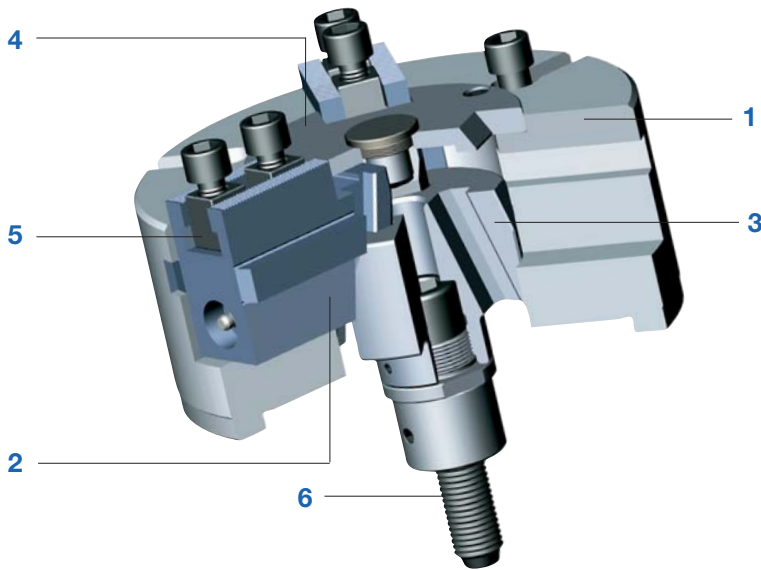

Components KFD

- 1. Body
- 2. Base jaw
- 3. Piston
- 4. Cover
- 5. T-nut
- 6. Draw bolt

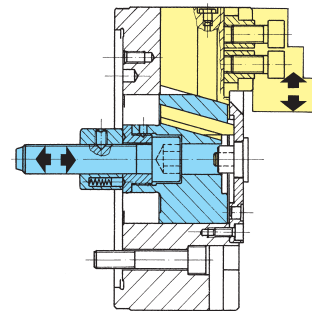

Design principle wedge system

On request:

KFD in customized version (with additional seal)

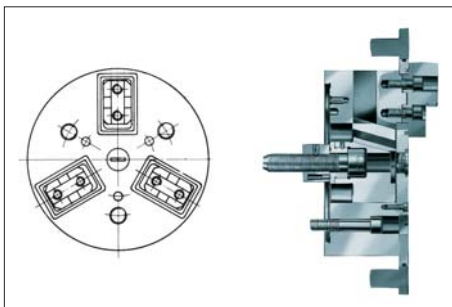

Type 538-40
Hermetically sealed for stationary attachment. Installation in transfer lines and rotary table machines

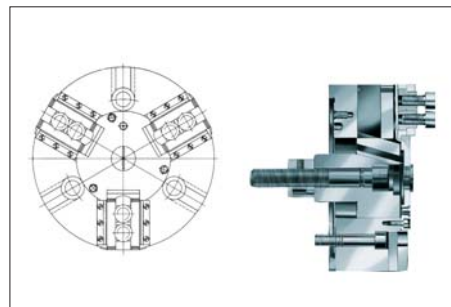

Type 538-42
Largely sealed with wiper blades. Mounting on lathes.

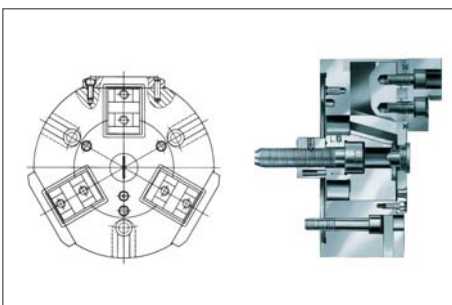

Type 538-41
Hermetically sealed for stationary or rotary attachment. Installation in transfer lines and rotary table machines in minimum amount of space.

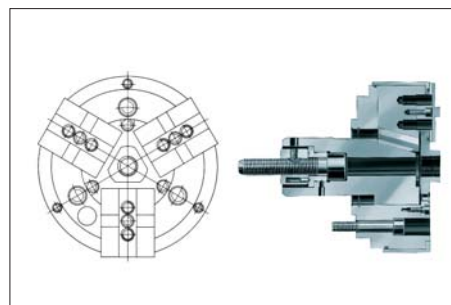

Type 538-43
Hermetically sealed for especially high chip and coolant accumulation on automats or production machines, rotating or stationary.

KFD 3-jaw, standard design, serration 90°

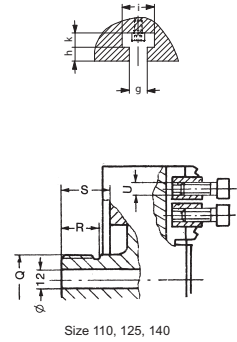
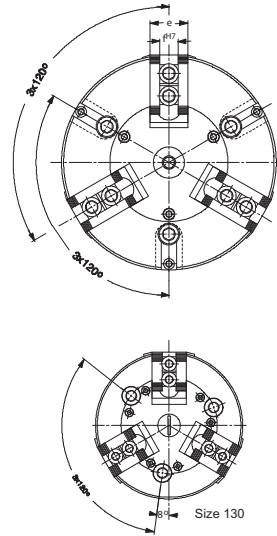
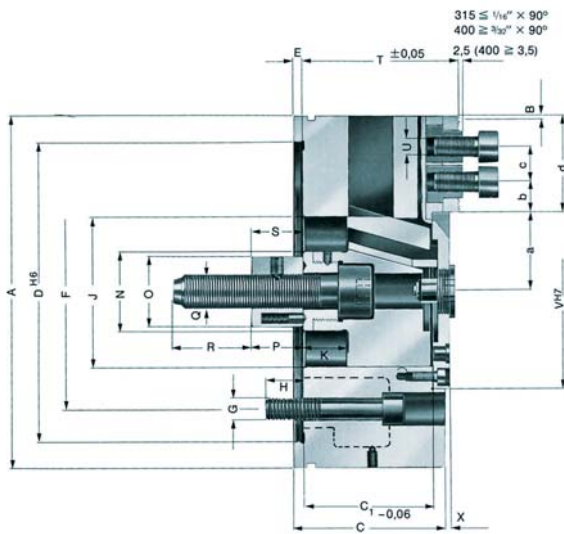

C15
3-jaw power chuck, standard design, serration 90°
Adaptor recess, mounting dimensions to DIN 6353

Item no.	004250	128405 ¹⁾	041240	023520	040630	144598	040653	040660	040669	040676
Size	110	125	130	160	200	250	315	400	500	630
A mm	110	125	130	160	200	250	315	400	500	630
Jaw travel B mm	2,1	3,7	5,3	5,3	6,7	6,7	8	9,3	9,3	10,5
C mm	31,5	40	69	79	87	102	117	127	127	140
C1-0,06 mm	28,55	37,05	58,05	66,05	74,05	89,05	104,05	111,05	111,05	125,05
Mount DH6	92	105	115	140	170	220	300	300	380	380
E mm	3	3	6	6	6	6	6	6	6	8
F mm	80	80	85	104,8	133,4	171,4	235	235	330,2	330,2
G mm	3 x M 8	3 x M 8	3 x M 10	3 x M 10	3 x M 12	3 x M 16	3 x M 20	3 x M 20	6 x M 24	6 x M 24
H mm	12	14	15	17	20	26	30	35	35	35
J mm	45	50	58	65	85	105	120	155	155	180
Wedge stroke K mm	8	14	20	20	25	25	30	35	35	40
N mm	-	-	35	35	45	55	60	60	60	80
O mm	-	-	34	34	40	46	46	55	55	55
P mm	-	-	25	25	30	30	30	30	30	30
Q mm	M20x1,5	M20x1,5	M 16	M 16	M 20	M 24	M 24	M 24	M 30	M 30
R mm	20	20	40	40	45	55	55	55	55	63
S min.	25	25	36	25	30	30	30	30	30	28
S max.	33	39	56	45	55	55	60	65	65	68
T±0,05 mm	34	44	73	80	90	105	120	130	130	148
U	M 6 x 18	M 6 x 18	M 8 x 20	M 12 x 25	M 12 x 25	M 16 x 30	M 16 x 30	M 20 x 40	M 20 x 40	M 20 x 40
VH7 mm	-	-	85	85	110	130	160	190	190	220
X mm	4	6	5	3	3	3	3	3	3	6
a min.	23,9	24,3	25	26,7	38,3	48,3	54	72,7	72,7	85,2
a max.	26	28	30,3	32	45	55	62	82	82	95,7
b min.	8,2	7	6	9	8	10	10	14	14	18
c min.	10	10	14	19	19	25	25	31	31	31
c max.	14,8	25	26	36,5	44,5	58,5	81,5	98	148	197
d mm	28	34,5	34,5	48	55	70	95	118	164	219,3
e mm	25	25	30	35	35	50	55	60	60	70
fh7 mm	10	10	12	17	17	21	21	25,5	25,5	25,5
g mm	-	-	-	14	14	18	18	22	22	22
h mm	-	-	-	11	11	13	13	22	22	22
i mm	-	-	-	25	25	32	32	40	40	40
k mm	-	-	-	11	11	14	14	18	18	18
Max. swing top jaws mm	172	192	184	215	290	345	410	560	660	790
Maximum draw bar pull kN	7	9	18	35	45	65	80	95	110	130
Max. total clamping force kN	12	15	35	70	90	140	190	250	300	360
Max. admissible speed min-1	4000	5000	5000	4500	4000	3200	2800	2000	1600	1200
Moment of inertia J kgm2	0,003	0,007	0,014	0,035	0,095	0,28	0,87	1,96	4,31	13,4
Weight without jaws approx. kg	2,1	3,6	6,8	10,9	19	35,5	70	98	138	270
Actuating cylinders (recommended)	OVS-85	OVS-85	OVS-85	OVS-105	OVS-130	OVS-150	OVS-150	OVS-200	OVS-200	OVS-200

¹⁾ Shallow design

KFD 3-jaw, standard design, tongue and groove

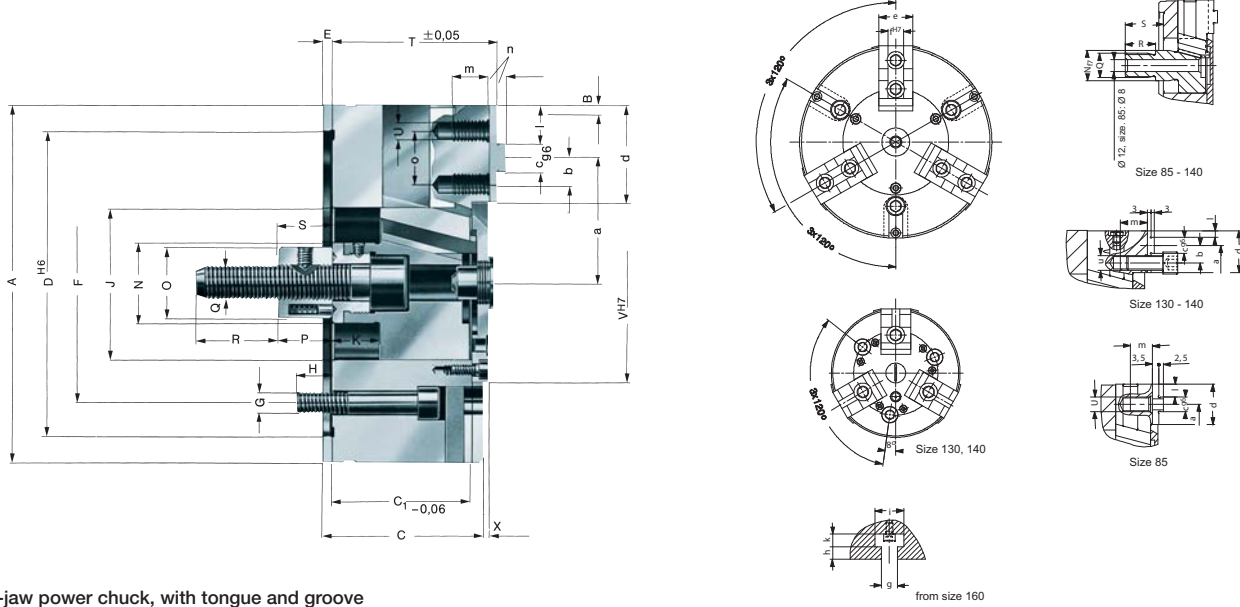

3-jaw power chuck, with tongue and groove
Adaptor recess, mounting dimensions to DIN 6353

Item no.	123110	004266	128427 ¹⁾	023529	040639	144604	144605 ▲
Size	85	110	125	160	200	250	315
A mm	85	110	125	160	200	250	315
Jaw travel B mm	2,6	2,1	3,7	5,3	6,7	6,7	6,7
C mm	31,5	31,5	40	79	87	102	102
C1-0,06 mm	28,55	28,55	37,05	66,05	74,05	89,05	89,05
Mount DH6	70	92	105	140	170	220	220
E mm	3	3	3	6	6	6	6
F mm	54	80	80	104,8	133,4	171,4	171,4
G mm	3 x M8	3 x M8	3 x M8	3 x M10	3 x M12	3 x M16	3 x M16
H mm	12	12	14	17	20	26	26
J mm	36	45	50	65	85	105	105
Wedge stroke K mm	10	8	14	20	25	25	25
N mm	20	-	-	35	45	55	55
O mm	-	-	-	34	40	46	46
P mm	-	-	-	25	30	30	30
Q mm	M16 x 1,5	M20 x 1,5	M20 x 1,5	M16	M20	M24	M24
R mm	20	20	20	40	45	55	55
S min.	25	25	25	25	30	30	30
S max.	35	33	39	45	55	55	55
T±0,05 mm	33	33	44	80	90	105	105
U	M8	M6	M6	M12	M12	M16	M16
VH7 mm	-	-	-	85	110	130	130
X mm	4	4	6	3	3	3	3
a min.	29,4	37,9	40,3	46,7	63,3	81,3	93,3
a max.	32	40	44	52	70	88	100
b mm	-	7,5	7,5	12,5	15	20	25
cg6 mm	8	8	8	10	12	16	16
d mm	22	28	34,5	48	55	70	102
e mm	20	25	25	35	35	50	50
fh7 mm	8	8	8	16	16	20	20
g mm	-	-	-	14	14	18	18
h mm	-	-	-	11	11	13	13
i mm	-	-	-	25	25	32	32
k mm	-	-	-	11	11	14	14
l mm	7	10	12,75	23	24	29	49
m mm	14	12	12	20	20	25	25
n mm	2,5	2,5	3	5	5	5	5
o mm	-	15	15	25	30	40	50
Maximum draw bar pull kN	7	7	9	35	45	65	75
Max. total clamping force kN	12	12	15	70	90	140	180
Max. admissible speed min-1	5000	4000	5000	4500	4000	3200	2800
Moment of inertia J kgm2	0,001	0,003	0,007	0,035	0,096	0,28	0,73
Weight without jaws approx. kg	1,3	2,1	3,7	11	19,2	36	59
Actuating cylinders (recommended)	OVS-85	OVS-85	OVS-85	OVS-105	OVS-130	OVS-150	OVS-150

¹⁾ Shallow design

Power chuck without through-hole KFD

KFD 3-jaw, weight reduced, serration 90°

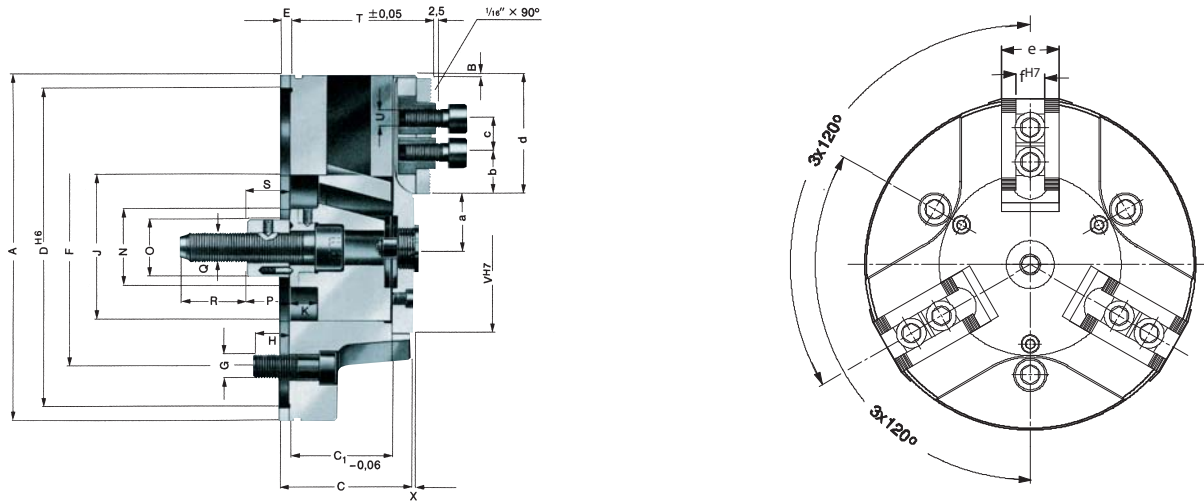

3-jaw power chuck, weight reduced, serration 90°
Adaptor recess, mounting dimensions to DIN 6353

Item no.	046730	046744	144594	144596
Size	160	200	250	315
A mm	160	200	250	315
Jaw travel B mm	5,3	6,7	6,7	6,7
C mm	79	87	102	102
C1-0,06 mm	66,05	74,05	89,05	89,05
Mount DH6	140	170	220	220
E mm	6	6	6	6
F mm	104,8	133,4	171,4	171,4
G mm	3 x M 10	3 x M 12	3 x M 16	3 x M 16
H mm	17	20	26	26
J mm	65	85	105	105
Wedge stroke K mm	20	25	25	25
N mm	35	45	55	55
O mm	34	40	46	46
P mm	25	30	30	30
Q mm	M16	M20	M24	M24
R mm	40	45	55	55
S min.	25	30	30	30
S max.	45	55	55	55
T±0,05 mm	80	90	105	105
U	M 12 x 25	M 12 x 25	M 16 x 30	M 16 x 30
VH7 mm	85	110	130	130
X mm	3	3	3	3
a min.	26,7	38,3	48,3	48,3
a max.	32	45	55	55
b min.	9	8	10	10
c min.	19	19	25	25
c max.	36,5	44,5	58,5	89,5
d mm	48	55	70	102,5
e mm	35	35	50	50
fH7 mm	17	17	21	21
Max. swing top jaws mm	215	290	345	410
Maximum draw bar pull kN	35	45	65	75
Max. total clamping force kN	70	90	140	180
Max. admissible speed min-1	4500	4000	3200	2800
Moment of inertia J kgm ²	0,027	0,076	0,226	0,496
Weight without jaws approx. kg	8,5	15,2	29	40
Actuating cylinders (recommended)	OVS-105	OVS-130	OVS-150	OVS-150

Power chuck without through-hole KFD

KFD 2-jaw, weight reduced, serration 90°

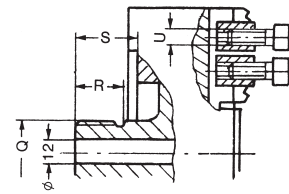
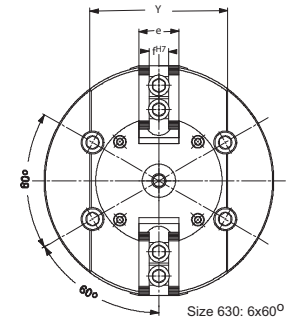
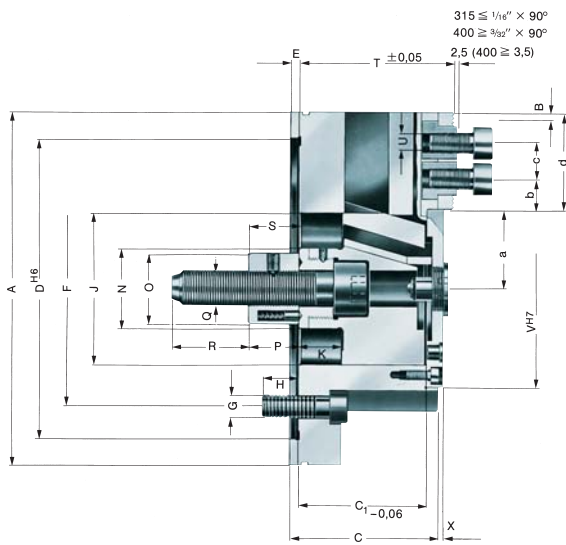

2-jaw power chuck, weight reduced, serration 90°
Adaptor recess, mounting dimensions to DIN 6353

Item no.	128409 ¹⁾	046736	046750	144608	045566	128421	128422 ▲	128423 ▲
Size	125	160	200	250	315	400	500	630
A mm	125	160	200	250	315	400	500	630
Jaw travel B mm	3,7	5,3	6,7	6,7	8	9,3	9,3	10,5
C mm	40	79	87	102	117	127	127	140
C1-0,06 mm	37+0,07	66,05	74,05	89,05	104,05	111,05	111,05	125,05
Mount DH6	105	140	170	220	300	300	380	380
E mm	3	6	6	6	6	6	6	8
F mm	80	104,8	133,4	171,4	235	235	330,2	330,2
G mm	4xM8	4 x M10	4 x M12	4 x M16	4 x M20	4 x M20	4 x M24	6 x M24
H mm	14	17	20	26	26	35	35	35
J mm	50	65	85	105	120	155	155	180
Wedge stroke K mm	14	20	25	25	30	35	35	40
N mm	-	35	45	55	60	60	60	80
O mm	-	34	40	46	46	55	55	55
P mm	-	25	30	30	30	30	30	30
Q mm	M20x1,5	M16	M20	M24	M24	M24	M30	M30
R mm	20	40	45	55	55	55	55	63
S min.	25	25	30	30	30	30	30	28
S max.	39	45	55	55	60	65	65	68
T±0,05 mm	44	80	90	105	120	130	130	148
U	M6x8	M12 x 25	M12 x 25	M16 x 30	M16 x 30	M20 x 40	M20 x 40	M20 x 40
VH7 mm	-	85	110	130	160	190	190	220
X mm	6	3	3	3	3	3	3	6
a min.	24,3	26,7	38,3	48,3	54	72,7	76,7	85,2
a max.	28	32	45	55	62	82	86	95,7
b min.	7	9	8	10	10	14	16	18
c min.	10	19	19	25	25	31	31	31
c max.	25	36,5	44,5	58,5	81,5	98	144	197
d mm	34,5	48	55	70	95	118	164	219,3
e mm	25	35	35	50	55	60	60	70
fH7 mm	10	17	17	21	21	25,5	25,5	25,5
Y mm	-	95	120	140	170	220	240	265
Max. swing top jaws mm	192	215	290	345	410	560	660	790
Maximum draw bar pull kN	6	23	30	43	55	65	75	90
Clamping force/jaw kN	6,5	25	33	48	62	75	85	120
Max. admissible speed min-1	5000	4500	4000	3200	2800	2000	1600	1200
Moment of inertia J kgm2	0,007	0,027	0,075	0,222	0,62	1,92	5,31	12,9
Weight without jaws approx. kg	3,6	8,5	15	28,5	53	96	170	200
Actuating cylinders (recommended)	OVS-85	OVS-85	OVS-105	OVS-130	OVS-130	OVS-150	OVS-200	OVS-200

¹⁾ chuck without weight reduction

Jaws KFD

C 21

Reversible top jaws, hardened serration 90° - material: 16 MnCr 5

Chuck Size	2-jaw set	3-jaw set	Jaw length mm	Jaw height mm	Jaw width mm	Serration
110/125	046545	046544	56	37,5	26	1/16"x 90°
130	045796	046404	56	37,5	26	1/16"x 90°
160/200	046429	046408	68	45	34,7	1/16"x 90°
160/200/250	118521	118522	75	49	36	1/16"x 90°
250/315	046435	046414	103,5	58	50	1/16"x 90°
400/500/630	046447	037531	135	65	68	3/32"x 90°

¹⁾ one step only

Additionally or later applied, hardened jaws must be ground out in the chuck.

C 21

Soft top jaws, can be hardened serration 90° - material: 16 MnCr 5

Chuck Size	2-jaw set	3-jaw set	Jaw length mm	Jaw height mm	Jaw width mm	Serration
110/125	045794	046402	53	30	22,5	1/16"x 90°
130	045795	046403	55	38	26,5	1/16"x 90°
160	133147	133152	66,7	53	36,5	1/16"x 90°
200	133148	133153	75	53	36,5	1/16"x 90°
250	133149	133154	95	54,5	45	1/16"x 90°
315	133150	133155	103	80	50	1/16"x 90°
400/500/630	133151	133156	130	80	50	3/32"x 90°
400/500/630	046446	046423	130	89	68	3/32"x 90°

C 21

Soft top jaws, can be hardened tongue and groove 120° bevelled, material: 16 MnCr 5

Chuck Size	3-jaw set	Jaw length mm	Jaw height mm	Jaw width mm
85	119459	40	30	22,5
110/125	046859	51	30	22,5
160	123358	72,7	53	36,5
200	123430	90,3	53	36,5
250	123433	115,3	54,5	45
315	129849	146	80	50

C 21

Claw-type jaws, 1 piece, hardened serration 90° - width of the groove 12

Item no.	Chuck Size	Jaw length mm	Jaw height mm	Claw length mm	Serration
144320	130	66	38	52	1/16"x 90°
144321	130	56	38	34	1/16"x 90°
144322	130	66	38	25	1/16"x 90°

C 21

Claw-type jaws, 1 piece, hardened serration 90° - width of the groove 17

Item no.	Chuck Size	Jaw length mm	Jaw height mm	Claw length mm	Serration
137031	160/200	67	45	53	1/16"x 90°
137032	160/200	65	45	46	1/16"x 90°
137039	160/200	55	45	40	1/16"x 90°
137034	160/200	50	45	31	1/16"x 90°
137035	160/200	55	45	27	1/16"x 90°
137036	160/200	65	45	19	1/16"x 90°
137037	160/200	65	45	26	1/16"x 90°
137038	160/200	55	45	24	1/16"x 90°
137033	160/200	55	45	39	1/16"x 90°

 Configure your individual clamping jaws online! www.web2product.biz

Jaws KFD

C 21

Claw-type jaws, 1 piece, hardened serration 90° - width of the groove 21



Item no.	Chuck Size	Jaw length mm	Jaw height mm	Claw length mm	Serration
137041	250/315	95	50	80	1/16"x 90°
137042	250/315	75	50	60	1/16"x 90°
137043	250/315	60	50	43	1/16"x 90°
137044	250/315	70	50	37	1/16"x 90°
137045	250/315	95	50	25	1/16"x 90°
137046	250/315	80	50	30	1/16"x 90°

C 21

Claw-type jaws, 1 piece, hardened serration 90° - width of the groove 25,5



Item no.	Chuck Size	Jaw length mm	Jaw height mm	Claw length mm	Serration
137051	400/500/630	130	65	113	3/32"x 90°
137052	400/500/630	90	65	67	3/32"x 90°
137053	400/500/630	100	65	45	3/32"x 90°
137054	400/500/630	130	65	33	3/32"x 90°

Accessories KFD

C 15

T-nuts

With screw

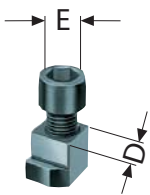

Item no.	Chuck Size	Contents of delivery	D mm	E
1305163	110/125	piece	10	M6x18
241673	130	piece	12	M8x20
241674	160/200	piece	17	M12x25
241675	250	piece	21	M16x30
241676	400/500/630	piece	25,5	M20x40

C 15

Special grease F80 for lathe chucks

for lubrication and conservation of clamping force



Item no.	Design	Contents
308555	Cartridge	0,5 kg
028975	Tin	1 kg

Accessories KFD

C 15

Intermediate adaptor plates with cylindrical centre mount DIN 6353 for 3-jaw chucks

Mounting from front to ISO 702-1 (DIN 55026/55021) and ASA B 5.9 A1/A2 with metric mounting bolts

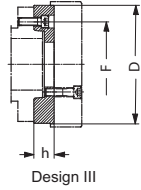
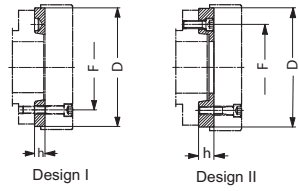

Item no.	Spindle nose size	Size	Design	h mm	F mm	D mm
145125 ¹⁾	4	160	II	18	82,6	140
145153	5	175	I	15	104,8	140
145127	5	200	II	21	104,8	170
145129	6	160	III	35	133,4	140
145155	6	200	I	16	133,4	170
145131	6	250	II	27	133,4	220
145135	8	200	III	39	171,4	170
145157	8	250	I	18	171,4	220
145137	8	315/400	II	38	171,4	300
145141	8	500/630	II	38	171,4	380
145143	11	250	III	48	235	220
145159	11	315/400	I	19	235	300
145145	11	500/630	II	40	235	380
145149	15	400	III	58	330,2	300
145161	15	400/500/630	I	21	330,2	380

All fastening parts are included
 Intermediate adaptor plate for 2-jaw version on request
 1) DIN 55021 on request

Jaw dimensions KFD / KFD-EC

Reversible top jaw UB,
hardened, serration 90°

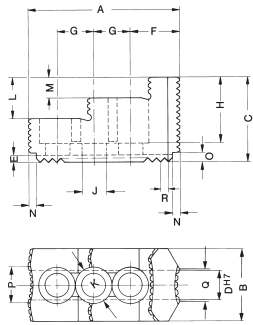

Chuck size	110/125/140	130	160	200/250 ¹⁾	250/315	400-800
Type	537-02	538-02	538-03	538-04	538-05	538-07 ²⁾
Item no. 2-jaw	046545	045796	046429	118521	046435	046447
Item no. 3-jaw	046544	046404	046408	118522	046414	037531
A	56	56	68	75	103,5	135
B	26	26	34,7	36	50	68
C	37,5	37,5	45	49	58	65
DH7	10	12	17	17	21	25,5
E	3,5	3,5	5	5	5	5
F	10	14	17	21,5	33,5	48
G	12 ³⁾	15	19	19	25	31
H	29	29	33,5	37,5	45	48
J	6,4	8,4	13	13	17	21
K	10,4	13,5	19	19	25	31
L	20	20	20	24	28	-
M	10	10	10	12	14	26
N	4	4	5	6	6	6,5
O	4	4	7	7,5	6,5	5,5
P	5	5	10	18	24,5	34
Q	5	5	5	7	22,5	40
R	1/16"x90°	1/16"x90°	1/16"x90°	1/16"x90°	1/16"x90°	3/32"x90°
Weight/jaw kg	0,130	0,170	0,350	0,460	1,130	2,000

1) Size 250: chuck in shallow design

2) one step only

3) 4 mounting holes

Soft top jaws AB,
Serration 90°
Module toothing
(Size 1000-1600)

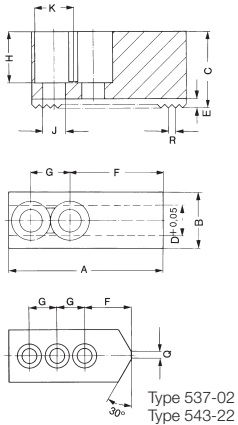

Chuck size	110/125/140	130	160	200/250 ¹⁾	250	315	400-800	400-800
Type	537-02	538-02	538-03	538-04	538-05	538-06	538-07	538-07 ²⁾
Item no. 2-jaw	045794	045795	133147	133148	133149	133150	133151	046446
Item no. 3-jaw	046402	046403	133152	133153	133154	133155	133156	046423
A	53	55	66,7	75	95	103	130	130
B	22,5	26,5	36,5	36,5	45	50	50	68
C	30	38	53	53	54,5	80	80	89
D	10	12	17	17	21	21	25,5	25,5
E	3,5	3,5	5	5	5	5	5	5
F	20	31	36	44	55	62	79	75
G	12 ³⁾	15	19	19	25	25	31	35
H	20	28	43	43	42,5	67	60	69
J	6,4	8,4	13	13	17	17	21	21
K	10,4	13,5	19	19	25	25	31	31
Q	3	-	-	-	-	-	-	-
R	1/16"x90°	1/16"x90°	1/16"x90°	1/16"x90°	1/16"x90°	1/16"x90°	3/32"x90°	3/32"x90°
Weight/jaw kg	0,223	0,320	0,700	0,880	1,400	2,580	3,1	5,120

1) Size 250: chuck in shallow design

2) heavy design

3) 3 mounting holes

Soft top jaws AB,
Tongue and groove

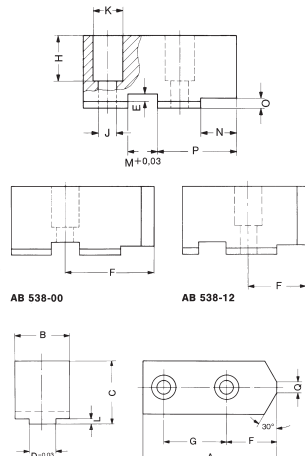

Chuck size	85	110/125 ¹⁾	160	200	250	315
Type	538-00	537-03	538-13	538-14	538-15	538-66
Item no. 3-jaw	119459	046859	123358	123430	123433	129849
A	40	51	72,7	90,3	115,3	146
B	22,5	22,5	36,5	36,5	45	50
C	30	30	53	53	54,5	80
D _{0,03}	8	8	16	16	20	20
E	3	3,5	5,5	5,5	5,5	5,5
F	29	29,5	32,5	45,3	58,3	63,5
G	-	15	25	30	40	50
H	20	20	38	38	38	60
J	9	6,4	13	13	17	17
K	15	10,4	19	19	25	25
L	2,5	2,5	4,5	4,5	4,5	4,5
M _{+0,03}	8	8	10	12	16	16
N	18	23	24,7	35,3	45,3	43
O	4	4	5	5	5	5
P	25	33	39,7	54,3	70,3	80,5
Q	3	3	3	6	6	6
Weight/jaw kg	0,146	0,200	0,720	1,000	1,550	3,600

1) chuck in shallow design

Jaw dimensions KFD / KFD-EC

Claw type jaws KB,
Serration 90°

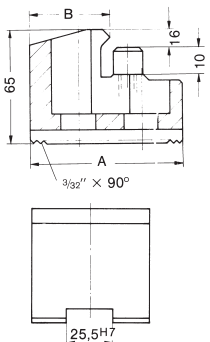
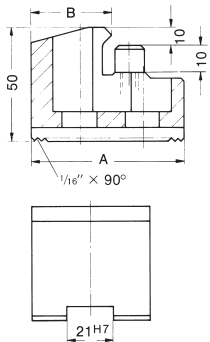
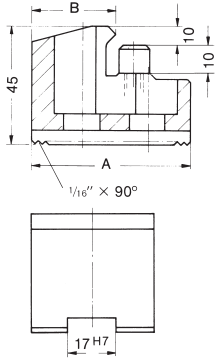
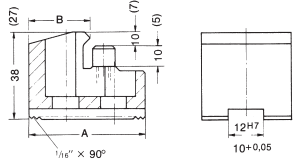

Size	A	B	130 External chucking
Item no. Piece			
144320	66	52	38-82
144321	56	34	78-122
144322	66	25	120-144
			Internal chucking
144322	66	25	70-98
144321	56	34	92-138
144320	66	52	122-178

Size	A	B	160 External chucking	200 External chucking
Item no. Piece				
137031	67	53	38-56	60-96
137032	65	46	51-71	73-111
137039	55	40	66-87	88-127
137034	50	31	83-102	105-142
137035	55	27	97-117	119-157
			Internal chucking	
137036	65	19	50-70	72-110
137037	65	26	68-85	90-125
137038	55	24	82-104	104-144
137035	55	27	102-116	124-156
137034	50	31	114-123	136-163
137039	55	40	120-135	144-175
137033	55	39	132-165	154-205
137032	65	46	146-178	168-218

Size	A	B	250 External chucking	315 ¹⁾ External chucking	315 External chucking
Item no. Piece					
137041	95	80	53-95	53-160	66-160
137042	75	60	92-133	92-198	105-198
137043	60	43	125-167	125-232	138-232
137044	70	37	156-198	156-263	169-263
			Internal chucking		
137045	95	25	68-112	68-117	81-177
137046	80	30	108-154	108-219	121-219
137044	70	37	146-186	146-240	159-240
137043	60	43	178-240	178-305	191-305
137042	75	60	212-265	212-330	225-330

¹⁾ chuck in shallow design

Size	A	B	400 External chucking	500 External chucking	630 External chucking
Item no. Piece					
137051	130	113	80-180	80-280	114-410
137052	90	67	170-270	170-370	204-500
137053	100	45	256-390	270-495	290-625
			Internal chucking		
137054	130	33	100-215	100-315	134-445
137053	100	45	260-395	275-500	295-625
137051	130	113	300-460	300-560	334-690

Chucking capacities KFD

Chucking capacities with reversible top jaw UB

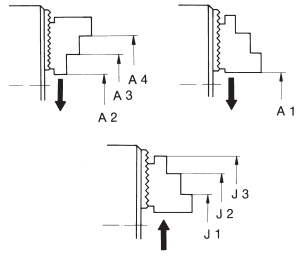

Chuck size		110	125	130	140	160	200	250 ¹⁾	250	315 ¹⁾	315	400	500	630
with reversible jaws	Type	537-02	537-02	538-02	537-02	538-03	538-04	538-04	538-05	538-05	538-05	538-07	538-07	538-07
	Jaw position													
External chucking	A1	4-62	4-78	6-66	4-93	5-73	16-108	16-159	20-124	20-189	34-189	40-225	40-325	60-450
	A2	-	-	-	-	-	28-118	28-169	38-152	38-217	52-217	70-280	70-380	108-510
	A3	47-105	75-126	60-119	75-140	70-140	86-173	86-223	120-232	120-297	134-297	-	-	-
	A4	82-140	110-161	94-151	110-176	110-182	137-224	137-274	200-314	200-379	214-379	275-480	275-580	310-700
Internal chucking	J1	40-95	40-110	42-96	40-125	53-120	70-156	70-208	70-170	70-233	84-233	102-305	102-405	136-530
	J2	74-130	72-145	74-130	72-160	92-163	120-208	120-258	146-251	146-313	160-313	-	-	-
	J3	112-168	116-190	118-175	116-205	144-200	173-261	173-311	236-328	236-393	250-393	295-490	295-590	328-720

¹⁾ chuck in shallow design

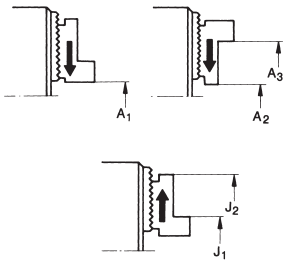

KFD-G



APPLICATION

Power chuck without through-hole for clamping workpieces with collars or shoulders (e.g. fittings), without having to give up high clamping force.

TYPE

Power chuck is available with cylindrical center mount.
2-jaw version with serration 90° (sizes 125 + 160 with tongue and groove).

CUSTOMER BENEFITS

- ③ Minimization of the interference contours of the chuck by means of bevels on the chuck body
- ③ Excessively high jaw stroke for flexible chuck use
- ③ Long service life - Sealed against dirt and water
- ③ High clamping precision thanks to proven wedge hook system

TECHNICAL FEATURES

- Power transmission by means of wedge hook system
- Direct lubrication of base jaws and pistons (4 lubrication points)
- Full steel design

Size 125 + 160
Tongue and groove

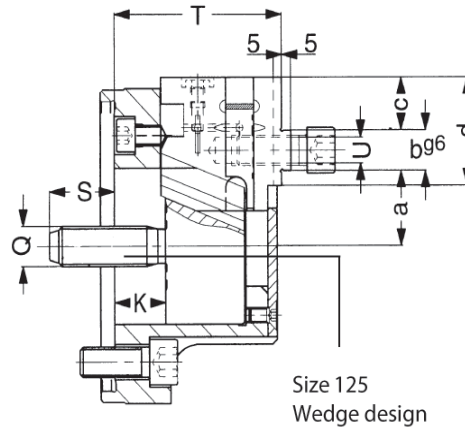
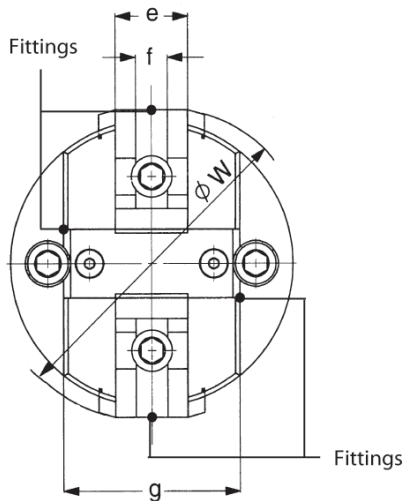

Size 125
Wedge design

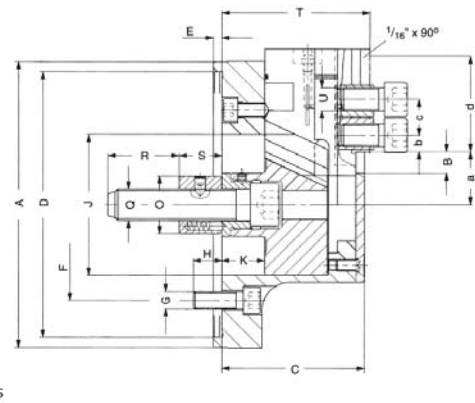
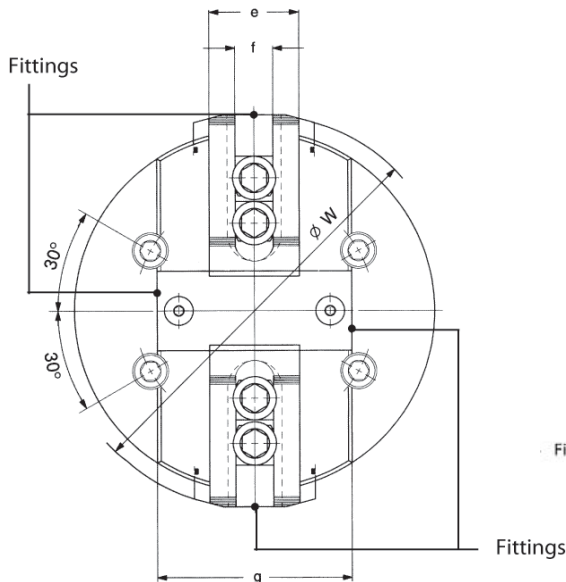

Fittings

KFD-G 2-jaw, large jaw movement, serration 90°

C15

2-jaw power chuck KFD-G, with large jaw movement,

Adaptor recess for clamping workpieces with collars or shoulders (e.g. fittings), without having to give up high clamping force.

Item no.	154025	154026	154027	154028	154029
Size	125	160	200	250	315
A mm	125	160	200	250	315
Jaw travel B mm	8,5	11	14	14,4	14,4
C mm	70	81	100	102	102
Mount DH6	115	140	185	220	220
E mm	6	6	6	6	6
F mm	92	104,8	133,4	171,4	171,4
G mm	2 x M 12	4 x M 10	4 x M 12	4 x M 16	4 x M 16
H mm	15	16	20	25	25
J mm	62	75	98	98	98
Wedge stroke K mm	22	27	30	31	31
O mm	-	35	44	44	44
Q mm	M 16	M 16	M 22	M 22	M 22
R mm	-	40	50	50	50
S min.	28	33	30	29	29
S max.	50	60	60	60	60
T±0,05 mm	72	84	103,7	105,7	105,7
U	M 12	M 16	M 16	M 20	M 20
WMax.	140	180	220	270	334
a min.	21,5	32,5	23	22,6	22,6
a max.	30	43,5	37	37	37
b min.	16g6	18g6	14	14	14
c min.	21	26	25	31	31
c max.	21	26	55,5	77	103
d mm	43	57,5	71,5	96	128,5
e mm	32	35	50	55	55
fH7 mm	14	18	21	25,5	25,5
g mm	78	91	108	120	120
Maximum draw bar pull kN	13	16	35	45	45
Max. total clamping force kN	10	12	25	29	29
Max. admissible speed min-1	3500	3000	3000	2500	2200
Moment of inertia J kgm2	0,01	0,04	0,09	0,2	0,4
Weight without jaws approx. kg	5	9	17	25	36,5
Actuating cylinders (recommended)	OVS-85	OVS-85	OVS-105	OVS-130	OVS-130

C 21

Soft top jaws, 2-jaw set, can be hardened tongue and groove for 2-jaw chucks, material: 16 MnCr 5



Chuck Size	2-jaw set	Jaw length mm	Jaw height mm	Jaw width mm
125	120321	56,5	53	36,5
160	120320	74,5	53	36,5

C 21

Soft top jaws, 2-jaw set, can be hardened serration 90° - material: 16 MnCr 5



Chuck Size	2-jaw set	Jaw length mm	Jaw height mm	Jaw width mm	Serration
200	120318	94	89	68	1/16"x 90°
200	133149	95	54,5	45	1/16"x 90°
250	120316	110	89	68	1/16"x 90°
315	120073	130	89	68	1/16"x 90°

Configure your individual clamping jaws online! www.web2product.biz

Special solutions - for power chucks without through-hole



KFD-HS oil - Power chuck with oil bath lubrication

APPLICATION

Ideal for use under extreme operating conditions thanks to hermetic seal against dirt and cooling water as well as no required maintenance, for the most time.

TYPE

2-, 3- or 4-jaw version with serration (90°) or tongue and groove. With short taper or cylindrical center mount.

CUSTOMER BENEFITS

- Largely maintenance-free thanks to constant lifetime lubrication of all moving parts through oil filling
- Hermetically sealed against dirt and cooling water
- Ideal for high speeds thanks to KFD-HS principle with simultaneously high concentricity and axial run-out

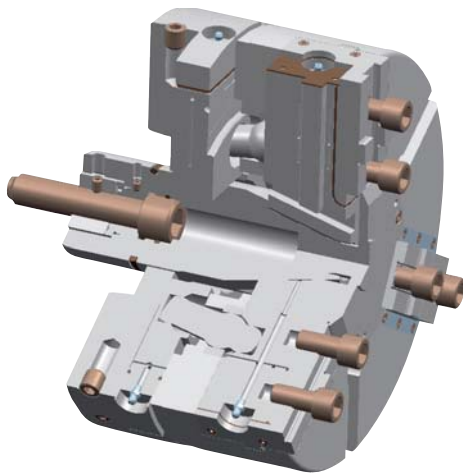

KFD-F-EC - Power chuck with centrifugal force compensation

APPLICATION

Especially for use under extreme operating conditions, e.g. dry or raw part machining and/or high coolant pressure with simultaneous centrifugal force-sensitive clamping.

TYPE

With centrifugal force compensation.

CUSTOMER BENEFITS

- Low-maintenance and -wear thanks to Easy Care
- Centrifugal force compensation for extremely high speeds



MSF - Diaphragm clamping chuck

APPLICATION

Optimally suited for grinding and hard turning with high precision.

TYPE

With quick-acting jaw change system via HSK interface and standard medium feed-through.

CUSTOMER BENEFITS

- Constant, uniform quality and clamping force thanks to diaphragm technology
- Contamination-resistant
- Quick-acting jaw change system via HSK interface for quick jaw change, maximum precision and change accuracy
- Nearly wear-free



Notes