

# HC-SE 3-Jaw Sealed Closed-center Chuck



## Application / Benefits

Ideal for vertical lathes and square or rectangular work that does not require a through-hole  
 Large sizes offered for large work  
 Sealed with wipers to minimize maintenance

## Technical features

Wedge hook style chuck with high gripping force

## ACTUAL GRIPPING FORCE DIAGRAM

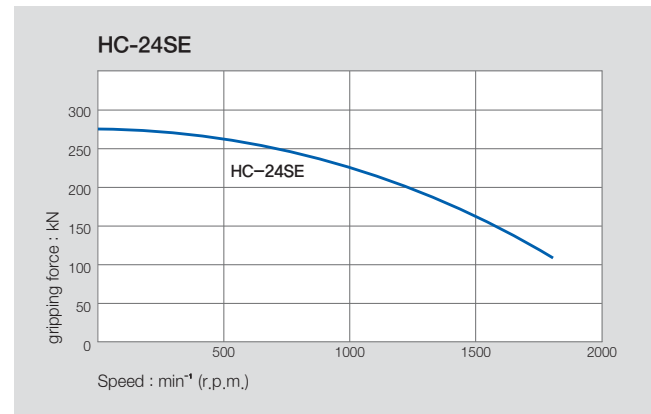
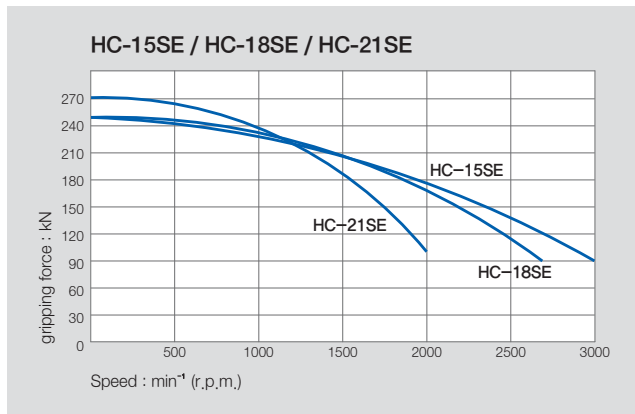

## SPECIFICATIONS

	HC-15SE	HC-18SE	HC-21SE	HC-24SE
Jaw Stroke Dia. [mm]	16	16	16	16
Plunger Stroke [mm]	35	35	35	35
Grip Dia. Max [mm]	381	450	530	610
Grip Dia. Min [mm]	71	133	62	152
Max. Permissible Input Force [kN(kgf)]	82(8362)	82(8362)	82(8362)	82(8362)
Max. Static Gripping Force [kN(kgf)]	249(25391)	249(25391)	273(27838)	273(27838)
Max. r.p.m. [min <sup>-1</sup> ]	3040	2710	1940	1760
Weight [kg]	96	124	180	223
Moment of inertia [N · m <sup>2</sup> (kg · m <sup>2</sup> )]	70.61(7.2)	92.2(9.4)	188.3(19.2)	271.6(27.7)
Max.hydraulic Pressure [MPa(kgf/cm <sup>2</sup> )]	3.2(32.6)	3.2(32.6)	3.2(32.6)	3.2(32.6)
Operating Cylinder Hydraulic	Y-2035R(RE)	Y-2035R(RE)	Y-2035R(RE)	Y-2035R(RE)
Operating Hard Jaw	HB15N1	HB15N1	HB18B2	HB18B2
KITAGAWA® Model	N-15	N-18	N-21	N-24

※ Specifications are subject to change without notice.  
 ※ HCF-12 is also available with long stroke.

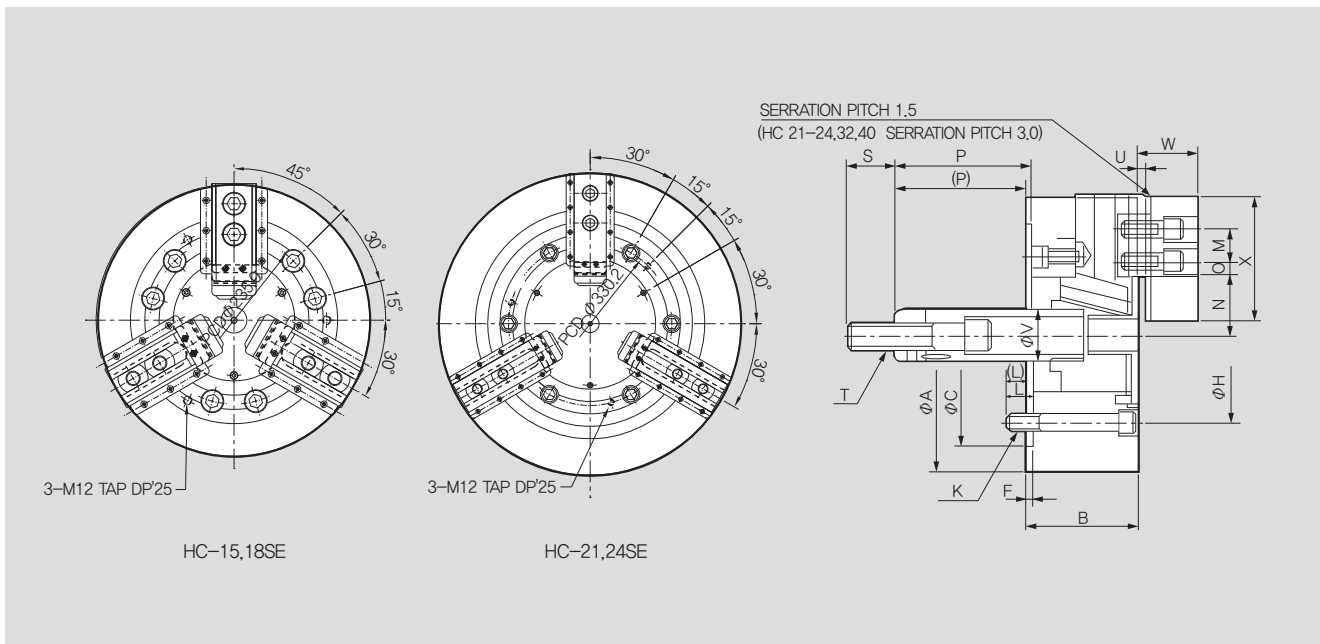

※ It is recommended to grease chucks at least twice a day in order to maximize longevity.

## DIMENSIONS

	HC-15SE	HC-18SE	HC-21SE	HC-24SE
$\Phi A$	381	450	530	610
B	114	114	125	125
$\Phi C(H6)$	300	300	380	380
F	6	6	6	6
$\Phi H$	235.0	235.0	330.2	330.2
J	-	-	-	-
K	6-M20x150	6-M20x115	6-M22x120	6-M22x120
L	65	30	31	31
M	43	43	60	60
N max.	77.5	108	86	125
N min.	69.5	100	78	117
O max.	48.75	48.75	93.5	93.5
O min.	23.25	23.25	27.5	27.5
P max.	104	92	97	97
P min.	69	57	62	62
Q	62	62	65	65
R	25.5	25.5	25	25
S	55	55	55	55
T	M30x3.5	M30x3.5	M30x3.5	M30x3.5
U	2	2	3	3
$\Phi V$	60	60	60	60
W	61	61	70	71
X	135	135	180	180

## RELATED PRODUCT

